

BIGFOOT

**4.25 IN./107.95MM
 TORPEDO DIA.**

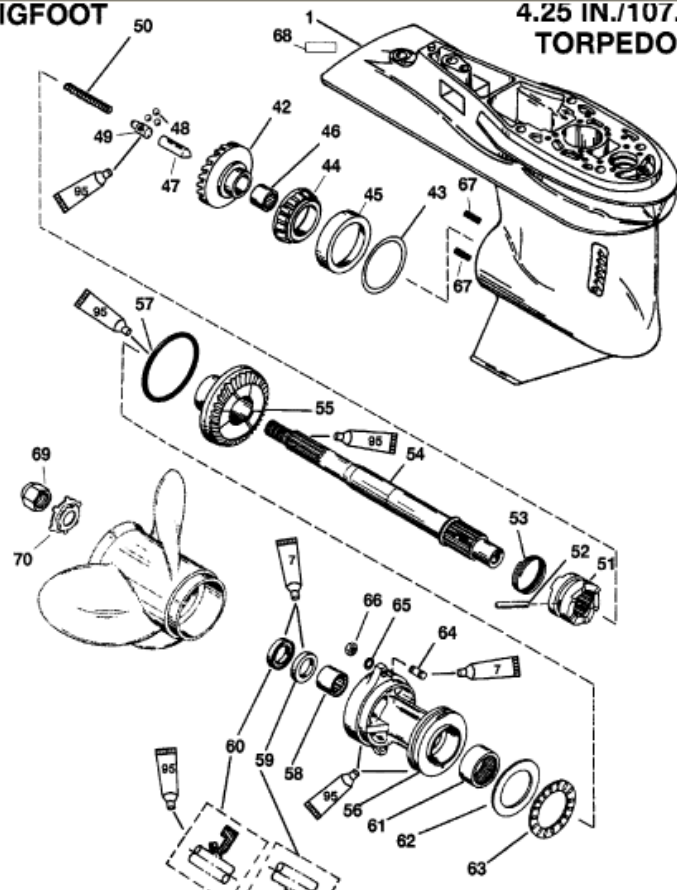

Quicksilver Lubrication/Sealant Application Points

- Loctite "271" Adhesive Sealant (92-809819)
- 2-4-C w/Teflon (92-825407A12)

A – TORQUE NUT TO 55 LB-FT (74.6 NM).

Parts List

Ref	Class	Part	Description	Qty	Comment	Footnote
-	1667	9011G43	GEAR HOUSING	1	(BLACK)	
-	1667	9011G44	GEAR HOUSING	1	(GRAY)	
1	1667	9011G59	GEAR HOUSING	1	(BASIC) (BLACK)	
1	1667	9011G60	GEAR HOUSING	1	(BASIC) (GRAY)	
42	43	850033A 2	FORWARD GEAR (30 TEETH)	1		
43	15	44491A 1	SHIM ASSEMBLY	AP		
44	31	30894A 1	TAPERED ROLLER BEARING	1		
45		NSS	CUP	1		
46	31	30895	ROLLER BEARING	1		
47		850315A 1	CAM FOLLOWER ASSEMBLY	1		
48	30	44530	BALL	3		
49		NSS	SLIDE	1		
50	24	850327	SPRING	1		
51	52	850048	CLUTCH	1		
52	17	30632	CROSS PIN	1		
53	24	30893	SPRING	1		
54	44	850308	PROPELLER SHAFT	1		
55	43	850034T	REVERSE GEAR (30 TEETH)	1		
56		12596T 2	BEARING CARRIER ASSEMBLY	1		
57	25	97386	O-RING	1		16
58	31	30956	ROLLER BEARING	1		
59	26	70080	OIL SEAL (INNER)	1		16
60	26	70081	OIL SEAL (OUTER)	1		16
61	31	12578	ROLLER BEARING	1		
62	12	12577	THRUST WASHER	1		
63	31	12576	THRUST BEARING	1		
64	16	42917 2	STUD (M8 X 48)	2		
65	12	855941	WASHER	2		
66	11	40119 8	NUT	2		
67		NSS	THREADED INSERT	2		
68		NSS	DECAL-GEAR CASE IDENTIFIC/	1		
69	11	52707A 1	PROP NUT	1		
70	14	816629	TAB WASHER	1		
-	26	43035A 4	G/H SEAL KIT	1		